

The ENERGIESTRO set is an **innovative** generating set specially designed for the **permanent long term power supply of installations not connected to the electric grid, or connected to a low quality grid**. Compared to existing solutions, the ENERGIESTRO set is more economical, more respectful of the environment and easier to operate.

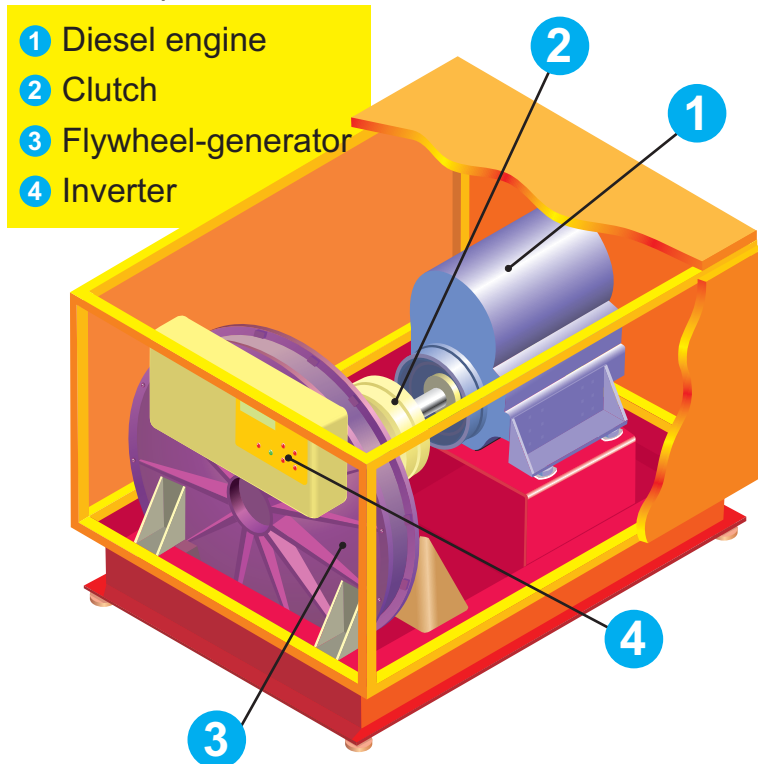

Description

The ENERGIESTRO set is comprised of a Diesel engine (1), a clutch (2), a flywheel-generator (3) and an inverter (4).

The flywheel-generator stands out because of:

- Its energy storage capability in its large diameter rotor;
- Its ultra low losses.

Off grid operation:

When the electric power required by the user is high, the ENERGIESTRO set operates continuously, at 1500 rpm, like a conventional gen-set. But when the electric power required by the user is low, **the operation is intermittent at variable speed**, alternating recharging periods (engine turning, flywheel-generator accelerating) and discharging periods (engine stopped, flywheel-generator decelerating).

Cogeneration: the heat produced during power generation is recovered, for instance for hot water production, which significantly improves energetic efficiency, and thus lowers operating costs and polluting emissions.

Grid connected operation:

While grid power is available, the engine stays stopped and short power disruptions are filtered out by the flywheel and the inverter. The engine starts operating only for grid outages longer than one minute. Thus the user enjoys an unlimited power supply of the best available quality.

Applications

- **Remote sites:** residential and professional sites not connected to the grid
- **Rural electrification** of developing countries
- **Zero emission buildings**, with the use of a biofuel (**renewable energy**)
- **UPS (Uninterrupted Power Supply)** where grid quality and reliability is low.

Benefits of Intermittent Operation

A conventional gen-set produces power only when the engine is turning. For uninterrupted power the gen-set must operate continuously, but this makes its life short, its maintenance frequent and its fuel consumption high: this is a very costly solution.

The intermittent operation of the ENERGIESTRO set makes engine life longer, maintenance less frequent and fuel consumption lower, as shown in the table:

Technology	ENERGIESTRO set	Conventional gen-set
Engine operation	Intermittent 10% (1,000 hours/year)	Continuous (10,000 hours/year)
Engine lifetime (engine life: 20,000 h)	20 years	2 years
Maintenance (interval: 1,000 h)	Yearly	Monthly
Parasitic power loss (compared to nominal power)	2%	> 20%

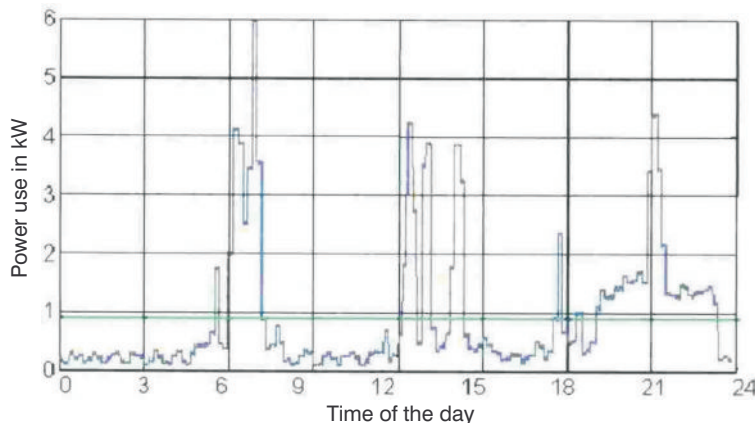

In fact, **intermittent operation is natural** in many applications, where rated power is very rarely used. The opposite curve shows the power use vs. the time of the day in a **residential** application: mean power is only one tenth of rated power.

In this case, the annual fuel consumption depends more on fuel consumption at low power (**parasitic loss**, which is never specified by gen-set makers) than on fuel consumption at rated power. **The opposite curve clearly shows the advantage of the ENERGIESTRO set: its parasitic loss is one tenth that of conventional gen-sets.**

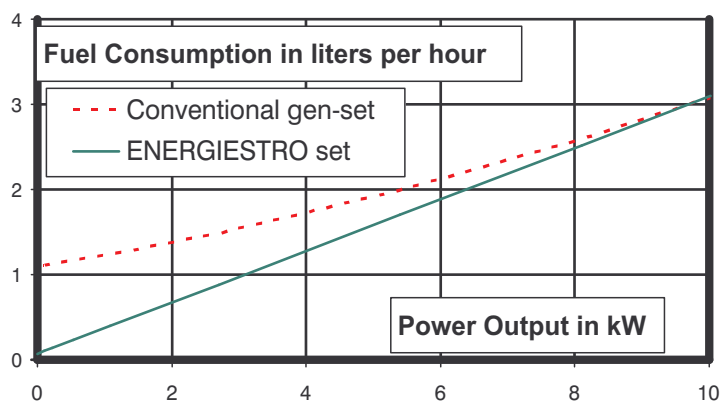

A parasitic fuel consumption of one liter per hour may seem unimportant, but it actually represents more than 8000 liters every year, much more than the “useful” fuel consumption.

Even professional applications consuming a constant electric power benefit from intermittent operation: when producing 1 kW constant power, a 10 kW intermittent ENERGIESTRO set has a much lower cost than a 1 kW continuous

operation conventional gen-set. The higher initial cost is quickly offset by the savings on maintenance, which is very expensive in the case of remote sites, and the extended engine life.

Advantages of flywheel over battery energy storage

The battery is practically the only energy storage technology currently used for energy supply of remote sites, but it is far from completely satisfying its users because it has lots of drawbacks. The flywheel rids users from these drawbacks, as shown in the following table.

Technology	Flywheel	Battery
Life	> 20 years (in practice infinite)	< 5 years (about 1000 cycles)
Life cycle cost	Low < 0,05 EUR/kWh	High > 0,20 EUR/kWh
Weight (10 kW residential application)	500 kg	1000 kg
Temperature sensitivity	No	High
Respect of environment	Yes (recyclable steel)	No (lead, cadmium)
Storage efficiency	> 80%	50 to 80%

The main drawback of the battery is its short life (which is never clearly specified by manufacturers). A high quality battery used in very good conditions will need to be changed after it has delivered 1,000 times its rated capacity, or after five years because it wears out even when not in use. In practice, a battery is very delicate and many factors diminish this theoretical life: wrong battery type, wrong maintenance, overcharge, deep discharge, high and low temperatures... Finally, the life cycle cost of the battery (all costs divided by the energy actually delivered) is about 0,30 EUR/kWh. **In residential applications, changing the battery costs 5,000 EUR every five years, and is a considerable maintenance work.**

On the contrary the flywheel has an infinite life, which results in a much lower life cycle cost than the battery, and a very light maintenance (no change required).

Finally, the battery contains lots of heavy metals, which are recyclable in theory, but in practice batteries are sold without control, so that a part of used batteries (about 5% in developed countries, much more in developing countries) is not recycled and seriously pollutes the environment. The flywheel, made of steel, is totally safe and recyclable.

Installation

The ENERGIESTRO set is designed to be installed outside, but can also be installed inside. Installation should be on a concrete slab with connections for electric power, fuel and hot water (in case of cogeneration).

Cogeneration

Standard ENERGIESTRO sets are cogeneration ready: the heat produced in the engine during power generation can be recovered as explained on the following diagram.

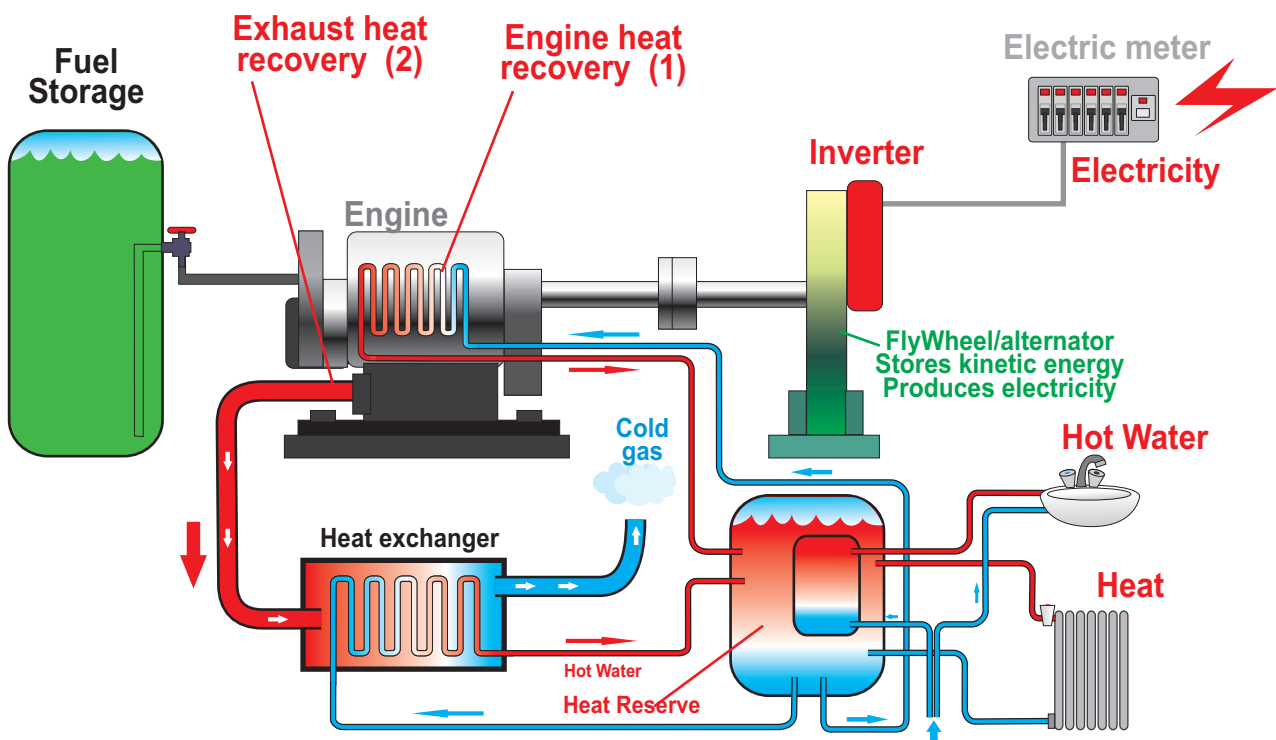

The engine cooling circuit can be sent (1) to a heat reservoir in the building, from which hot water and space heating are produced. The amount of heat recovered is roughly equal to the amount of electric power produced. **In residential applications, this is sufficient to cover the hot water needs free of charge.** When the heat reservoir is full, excess heat is classically dissipated by the engine radiator.

An optional heat exchanger further recovers exhaust heat (2), doubling the amount of heat recovered and pushing thermal efficiency to 90%. **In residential applications, this enables to cover free of charge the heating needs of a sufficiently insulated house.**

Biofuels

Biofuels are the various fuels produced from biological processes, like agriculture and waste treatment. They have numerous advantages over fossil fuels, in particular they produce much less GHG (glasshouse gases). Biofuels are a **sustainable** solution of world energy problems, in that they are renewable (they are actually **solar** energy stored in chemical form), economical (their final cost is nearly that of fossil fuels with taxes) and very abundant.

The ENERGIESTRO set used with a biofuel is a **true renewable energy**, like solar and wind energy, but more economical and practical.

The standard ENERGIESTRO set can be used with two biofuels:

- **Pure plant oil;**
- **Biodiesel** (fatty acid ester), which is a normalized fuel.

Depending on demand, we will develop ENERGIESTRO sets adapted to other biofuels: biogas, ethanol...

Which model to choose?

The ENERGIESTRO set is designed to replace the electric grid: choose the model with the same power rating than the subscription you would have chosen if the grid were available.

In residential applications (fluctuating power consumption), the 5 kW set gives a good comfort, but you cannot use simultaneously powerful appliances. The 10 kW let you enjoy modern comfort without restriction.

In professional applications (constant power consumption), the rule is to choose the set with a power rating ten times larger than the power consumption: for instance the 10 kW set is adapted to power constant loads up to 1 kW.

Case study: off grid residential application

Comparison of the 10 kW ENERGIESTRO set with three competing technologies:

- Conventional gen-set: 6 kW, diesel engine, 1,500 rpm, sound insulation.
- Solar: photovoltaic panels 5 kW peak (about 50 m²), battery 48 V 500 Ah (one ton!), inverter 6 kW, gen-set 6 kW.
- Conventional gen-set + battery: same system without solar panels.

Specifications :

- Annual power consumption: 4000 kWh
- Fuel cost: 0,40 EUR/liter

The following diagrams show the initial cost divided by the rated power and the operating cost divided by the energy consumption:

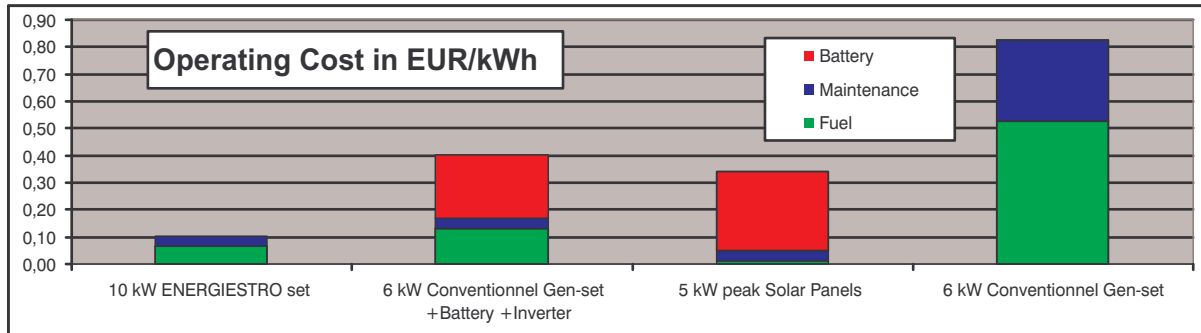
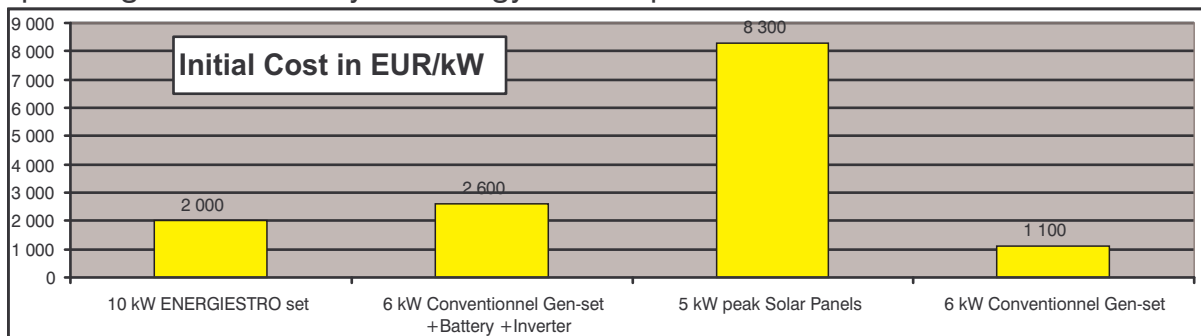

The following diagram combines the previous ones over a long period:

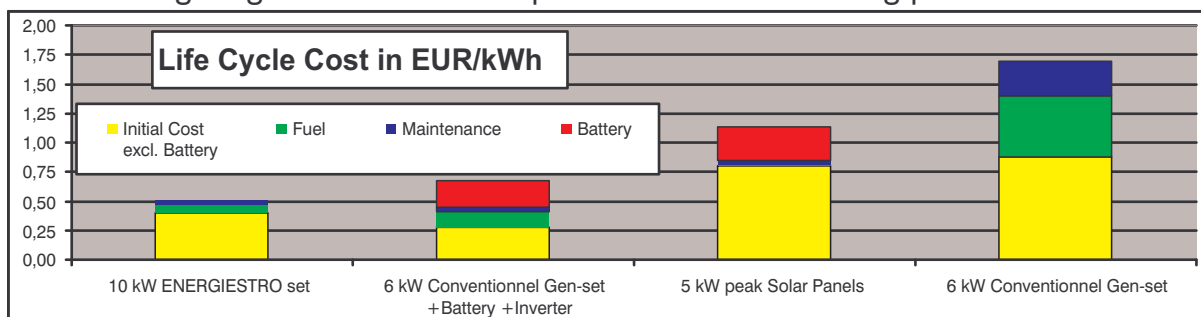

The ENERGIESTRO set is the most economical solution, thanks to its ultra low operating cost, the same as the grid! It is also **the most comfortable solution**: highest power and no battery change.

The conventional gen-set, in spite of its low initial cost, is the most expensive solution.

Solar panels is a huge investment, with a surprisingly high operating cost, because of the battery.

Case study: off grid professional application

Comparison of the 10 kW ENERGIESTRO set with three competing technologies:

- Conventional gen-set: 1 kW, diesel engine, 1,500 rpm.
- Solar: photovoltaic panels 10 kW peak (about 50 m²), battery 48 V 1000 Ah, inverter 1 kW, gen-set 10 kW.
- Conventional gen-set + battery: same system without solar panels.

Specifications :

- Power: 1 kW continuous (annual power consumption: 9000 kWh)
- Maintenance: every 1000 hours, cost 500 EUR (travel)
- Fuel cost: 0,40 EUR/liter

The following diagrams show the initial cost divided by the rated power and the operating cost divided by the energy consumption:

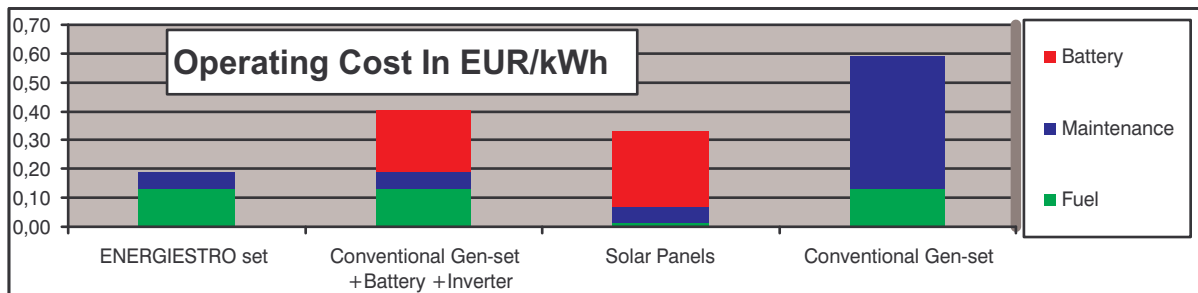
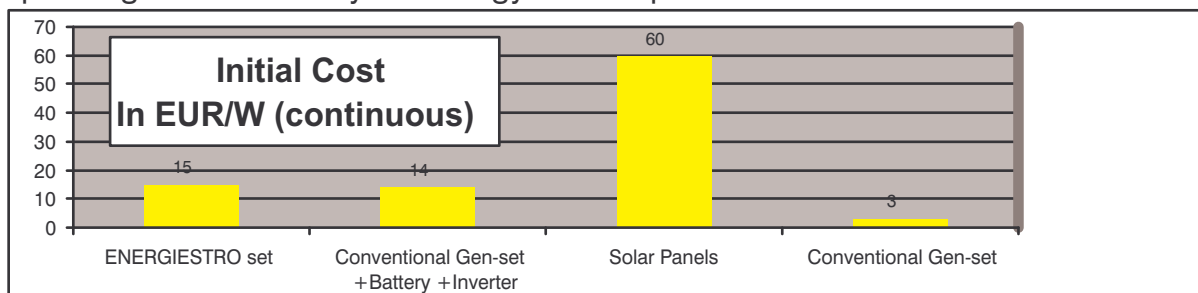

The following diagram combines the previous ones over a long period:

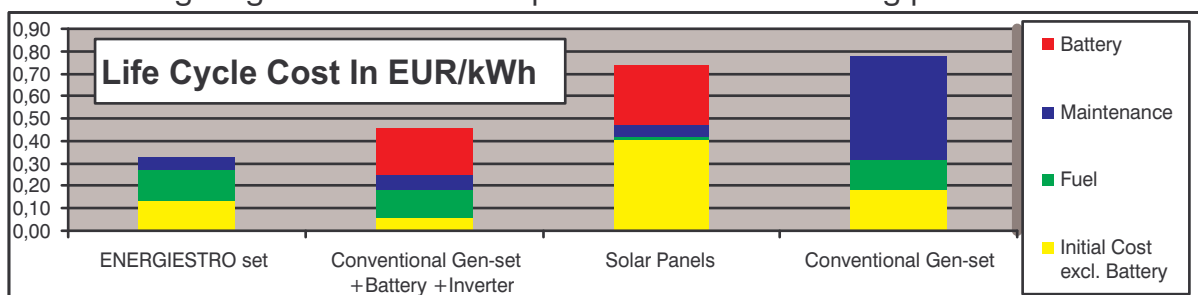

The ENERGIESTRO set is the most economical solution, thanks to its ultra low operating cost.

The conventional gen-set, in spite of its low initial cost, is the most expensive solution.

Solar panels is a huge investment, with a surprisingly high operating cost, because of the battery.

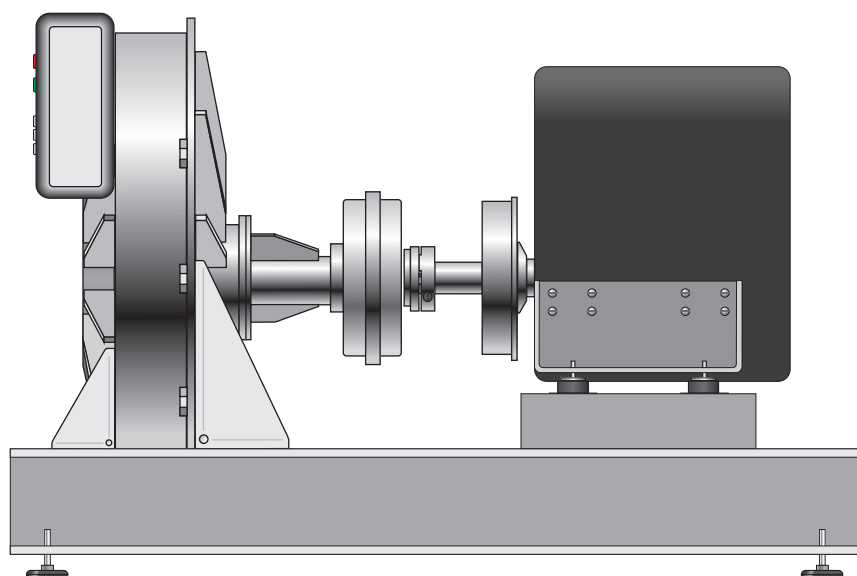

Common Specifications

Voltage	1 phase : 115 or 230 V 3 phase : 400/230 V
Frequency	50 or 60 Hz
Overload	100% for 1 s 10% for 1 min
Noise level	standard : 85 Lwa or 62 dB(A) @ 7 m optional : 73 Lwa or 50 dB(A) @ 7 m
Fuel	standard : diesel, biodiesel, pure plant oil optional : propane, natural gas, biogas
Efficiency (e)	e=30%, or about 3 kWh electric power per liter of fuel
Cogeneration	standard : heat recovery on cooling circuit (e=60%) optional : heat recovery on exhaust (e=90%)
Maintenance	Every year : fluid levels, oil and filter change Every five years : engine, clutch and bearing control
Life	Minimum 20 years

Range

Rated power (kW)	5	10	20	50	100
Phase	1	1 or 3	3	3	3
Fuel consumption (liters per hour)					
• Parasitic (no load)	0,04	0,06	0,11	0,3	0,5
• @ rated power	1,7	3,3	6,5	15	30
Dimensions width x length height (cm)	100 x 100 100	100 x 120 100	125 x 140 125	150 x 180 150	150 x 270 150
Weight (with noise insulation, radiator, exhaust) (kg)	700	1 000	1 900	3 100	5 400

ENERGIESTRO
1, rue du Haut-Perreux
28200 Conie-Molitard
France

contact@energiestro.com
+33 (0) 237 961 540